

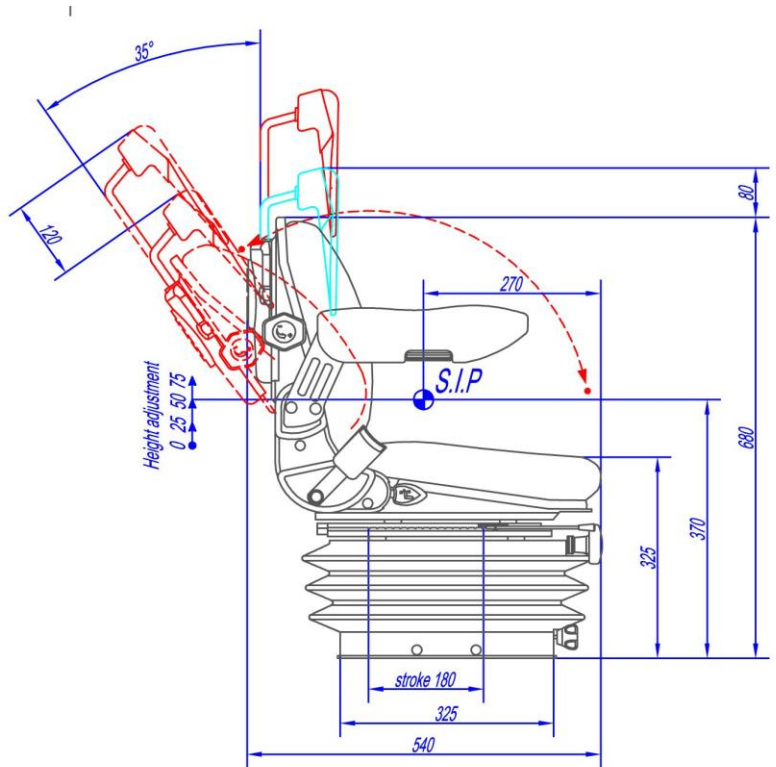

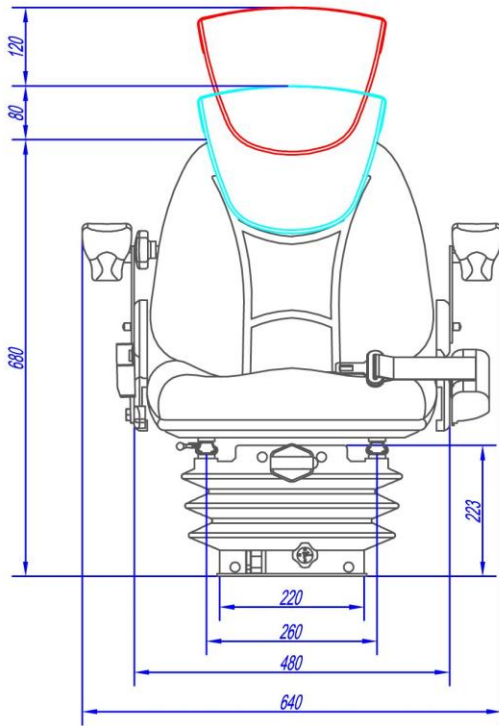

Cap. Soc. Euro 50.000,00 i.v.  
Cod. Fisc. e P. I.V.A. 00385780200  
Iscr. R.E.A. MN n. 129758  
Iscr. R.I. MN n. 00385780200  
Num. Mecc. MN 002179  
Cod.Id. INTRACOMUN. IT.00385780200

Via Veneto, 6 A-B  
46029 SUZZARA  
MANTOVA - ITALY  
Tel. +39 - 0376 536541  
Fax +39 - 0376 521723  
info@agriexport.it.



SUSPENSION MECANIQUE

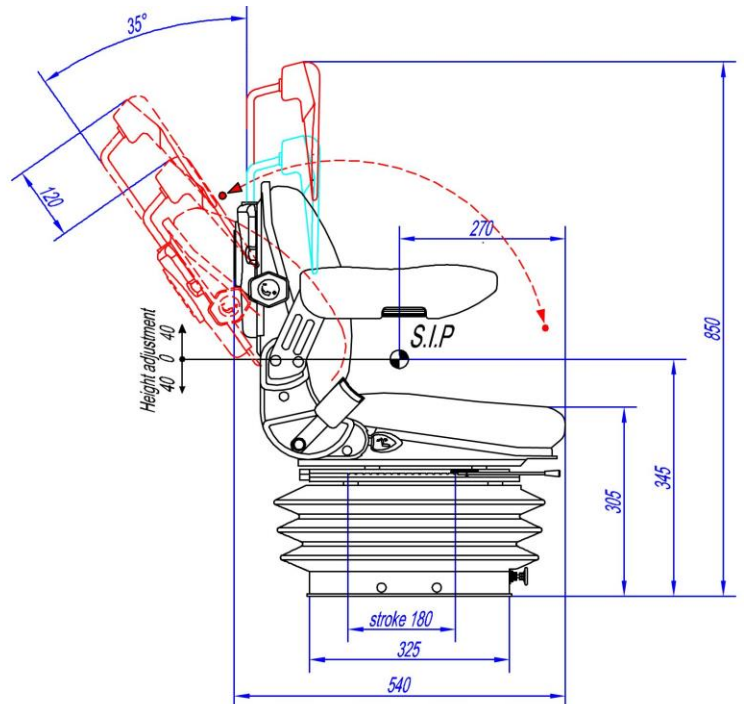
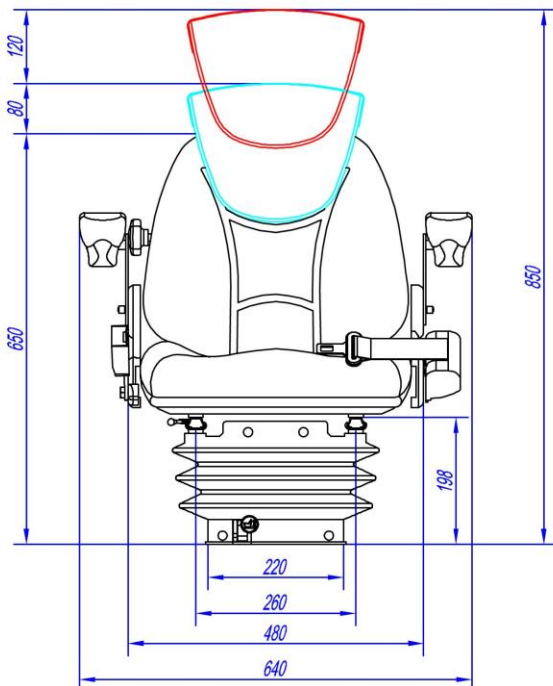

SUSPENSION PNEUMATIQUE