

NOTICE DE MONTAGE-ASSEMBLY INSTRUCTIONS-MONTAGEANLEITUNG- MANUAL DE MONTAJE- MANUAL DE MONTAGEM

creador
inspired by nature

KIOSKO

MWH Code: 878138

Tonnelle rectangulaire en aluminium

GFA30729W

IMPORTANT : A CONSERVER POUR CONSULTATION ULTERIEURE CLASSE D'UTILISATION DOMESTIQUE

BIEN ETUDIER LA NOTICE DE MONTAGE
REPEREZ LES PIECES CONSTITUANT VOTRE
MEUBLE
REGROUPEZ ET CONTROLEZ LA QUINCAILLERIE
MUNISSEZ-VOUS DE L'OUTILLAGE NECESSAIRE
AMENAGEZ-VOUS UNE ZONE DE MONTAGE
PROCEDEZ AU MONTAGE
NE JAMAIS FORCER LES ASSEMBLAGES
RESSERREZ LES VIS APRES QUELQUES TEMPS
D'USAGE
GARDER VOTRE NOTICE DE MONTAGE, SI UNE PIECE
VENAIT A MANQUER, ELLE SERAIT LE
PLUS CLAIR MOYEN DE COMMUNIQUER AVEC
VOTRE MAGASIN.

READ THE ASSEMBLY INSTRUCTIONS CAREFULLY
IDENTIFY THE ELEMENTS CONSTITUING YOUR
PIECE OF FURNITURE
GROUP AND CHECK THE HARDWARE FITTINGS
GET THE TOOLS NEEDED
CLEAR SPACE TO WORK
PROCEED TO ASSEMBLE
NEVER FORCE THE FITTINGS
TIGHTEN THE SCREW AFTER USING FOR
SOMETIME
KEEP YOUR ASSEMBLY INSTRUCTIONS, IT
COULD HELP FOR BETTER COMMUNICATION
WITH YOUR STORE, IN THE EVENT OF QUERY.

DIE MONTAGEANLEITUNG SORGFÄLTIG DURCHLESEN
DIE EINZELTEILE DES MÖBELSTÜCKS ERMITTELN
DIE BESCHLÄGE ZUSAMMENLEGEN UND PRÜFEN
DAS NOTWENDIGE WERKZEUG ZURECHTLEGEN
EINEN MONTAGEBEREICH FREIMACHEN
DAS MÖBEL STÜCK ZUSAMMENBAUEN
NIEMALS DIE VERBINDUNGEN ZU STARK ANZIEHEN
DIE SCHRAUBEN NACH EINIGER ZEIT DES
GEBRAUCHS ERNEUT FESTZIEHEN
DIE MONTAGEANLEITUNG GUT AUFBEWAHREN:
SOLLTE EIN TEIL FEHLEN, IST SIE DAS BESTE
VERSTÄNDIGUNGSMITTEL MIT IHREM GESCHÄFT

ESTUDIE ATENTAMENTE EL MANUAL DE
MONTAJE
LOCALICE LAS PIEZAS QUE CONSTITUYEN SU
MUEBLE
REUNA Y CONTROLE LOS TORNILLOS
EQUIPE-SE DE LAS HERRAMIENTAS
NECESARIAS
PREPARE UMA ZONA DE MONTAJE
REALICE EL MONTAJE
NO FUERCE NUNCA EN LAS UNIONES
APRIETE LOS TORNILLOS DESPUES DE CIERTO
TIEMPO DE UTILIZACION
CONSERVE SU MANUAL DE MONTAJE, SI
FALTARA UNA PIEZA, SERIA LA MANERA MAS
FACIL DE COMUNICAR CON LA TIENDA

LEIA ATENTAMENTE O MANUAL DE INSTALAÇÃO
IDENTIFICAR OS ELEMENTOS ESTÃO SEUS MÓVEIS
AGRUPE E VERIFIQUE OS PARAFUSOS
EQUIPE-SE DAS FERRAMENTAS NECESSÁRIAS
PREPARAR UMA ÁREA DE MONTAGEM
REALICE O MONTAGEM
NUNCA FORCE NAS UNIÕES
APERTAR DEPOS DE ALGUM TEMPO DO USO
GUARDE AS INSTRUÇÕES, SE FALTA UMA PEÇA A
MANEIRA MAIAS FÁCIL ES COMUNICAR A LOJA

Vérifiez régulièrement que les vis sont bien serrées et les
resserrer si besoin, si le montage n'est pas bien réalisée cela
peut endommager le produit et être dangereux lors de son
utilisation

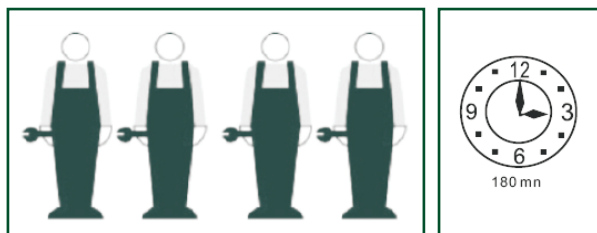
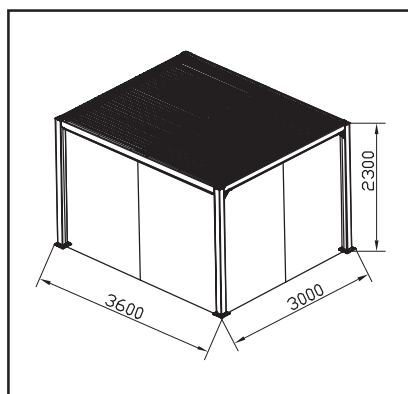
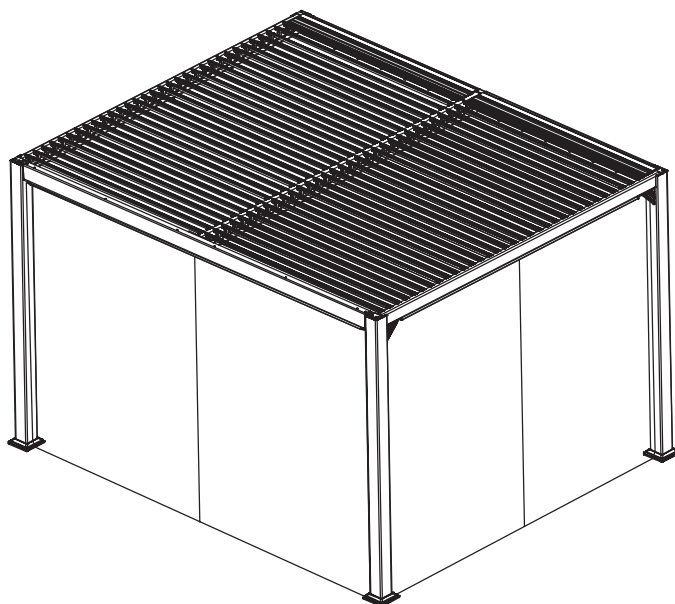

Elément : matériau.





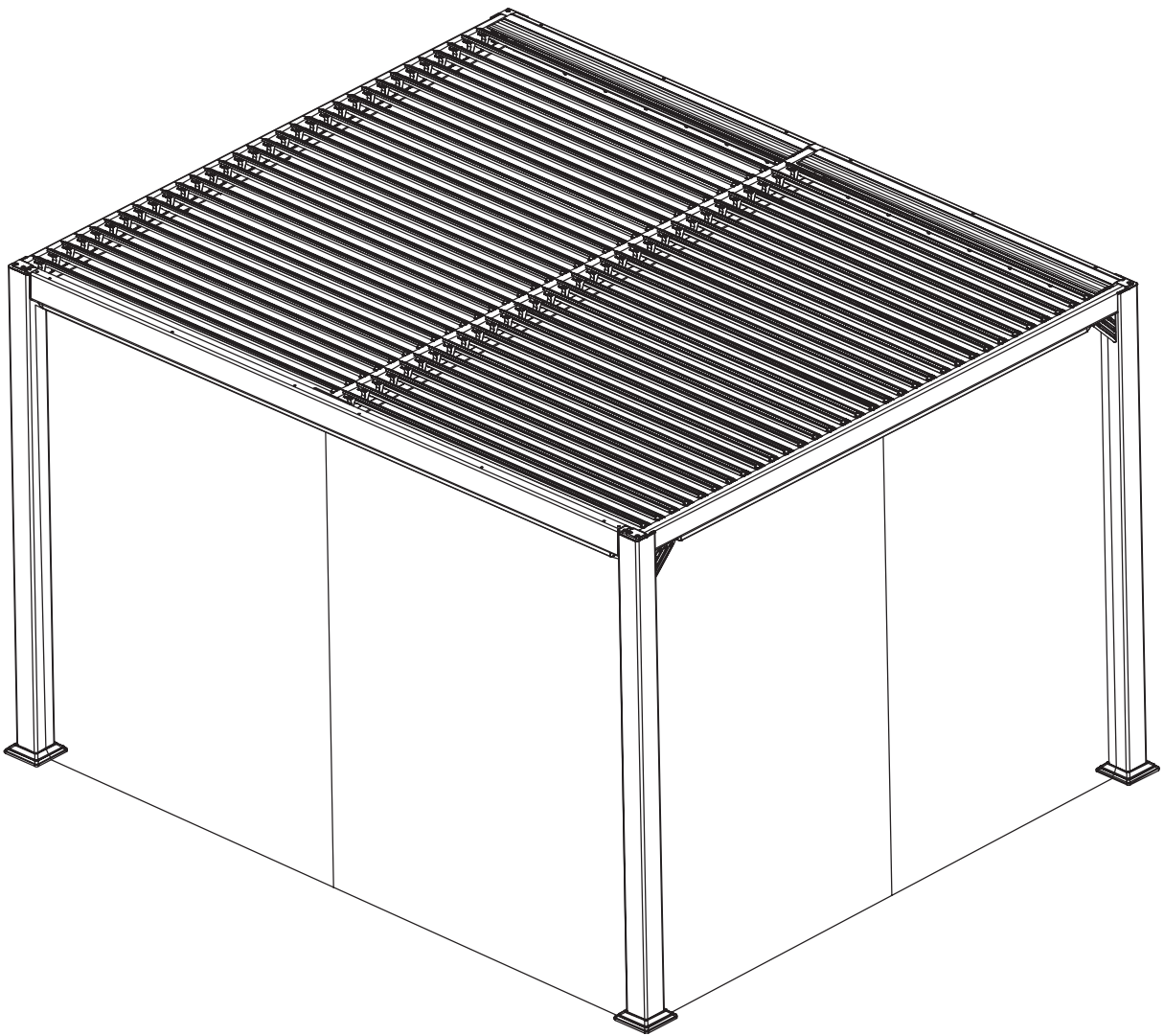





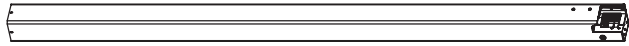

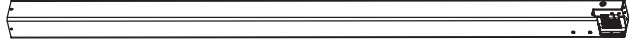





Structure en aluminium traitée epoxy
Toile polyester







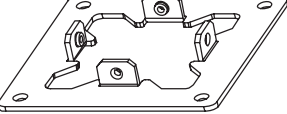
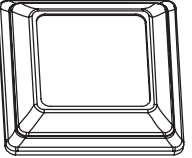
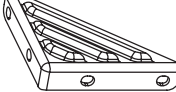

**VUE ÉCLATÉE-EXO-EXPLODED VIEW
AUSEINANDERGEZOGENER PERSPEKTIVSCHNITT
VISTA DESPIEZADA-VISTA EXPLODIDA**

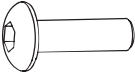

**QUINCAILLERIE-HARDWARE
 BESCHLÄGE-FERRETERIA
 -PARAFUSOS**

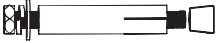

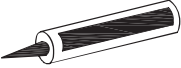

**OUTILLAGE-TOOLS-WERKZEUG
 HERRAMIENTA
 -FERRAMENTAS**

REF	PCE	PIECE	QTY	DIM
	A1			2
	A2			2
	B			2
	C1			1
	C2			1
	D			1
	F			64
	G			2
	H			4
	J			4
	M			4
	P			2

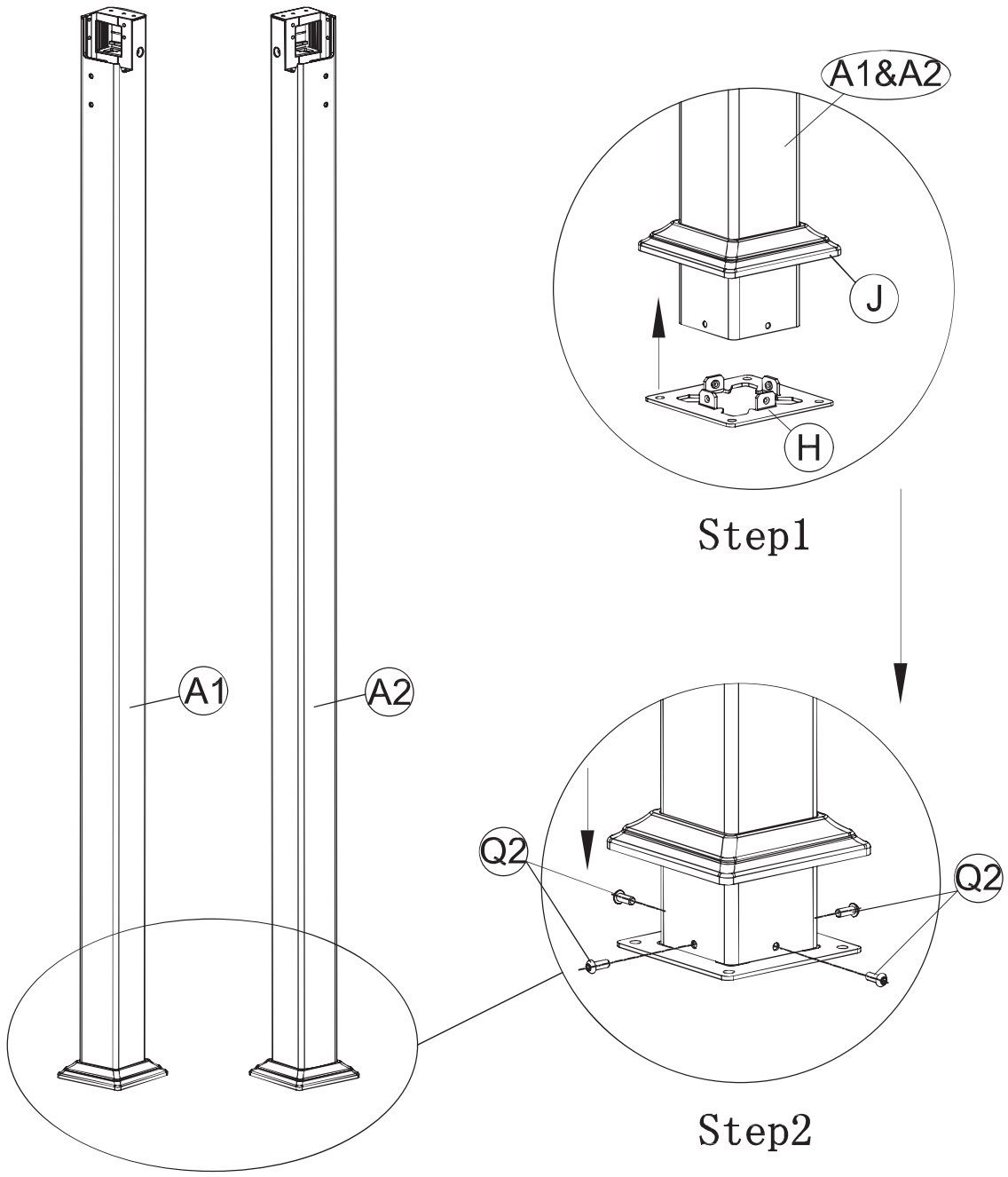
REF	PCE	PIECE	QTY	DIM
	T		4	
	Q1	 M8*20	52+2	
	Q2	 M6*15	16+2	
	Q3	 M6*15	6	
	Q4	 M4*18	2	
	Q5		16+2	
	R		1	
	S1		2	
	S2		1	
	S3		1	
	U	 Silicone non fourni	0	

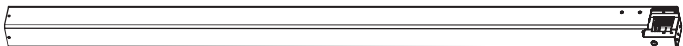
STEP 01

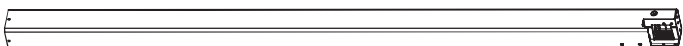

	<input type="checkbox"/> A1	(X2)		H	(X4)
	<input type="checkbox"/> A2	(X2)		J	(X4)
	M6*15	Q2	(X16)		

STEP 02

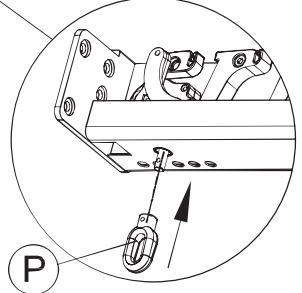
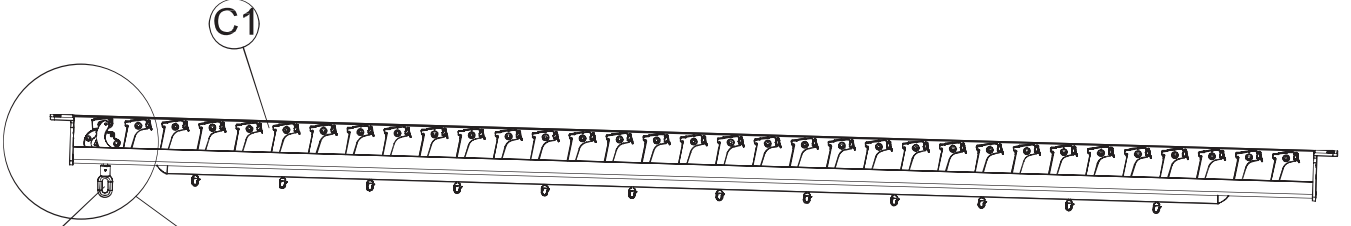

Step1

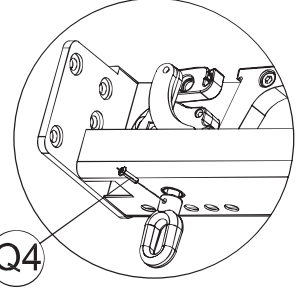

Step2

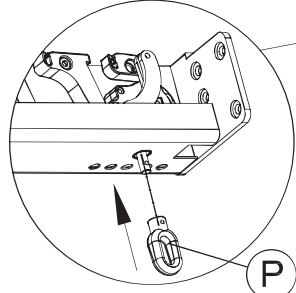
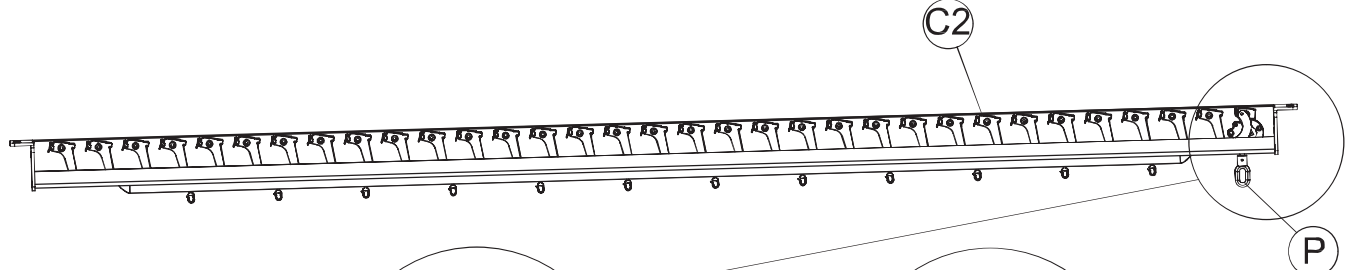

Step1

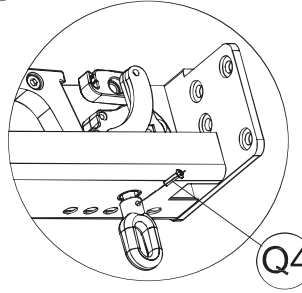

Step2



	⌋	C1 (X1)
	⌋	C2 (X1)
	P	(X2)
	M4*18	Q4 (X2)

STEP 03

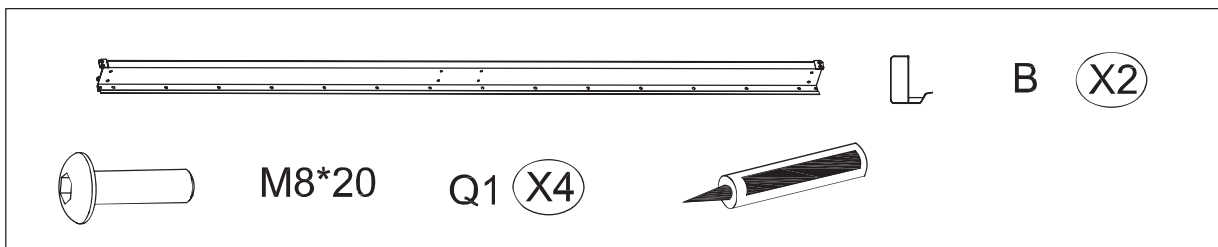
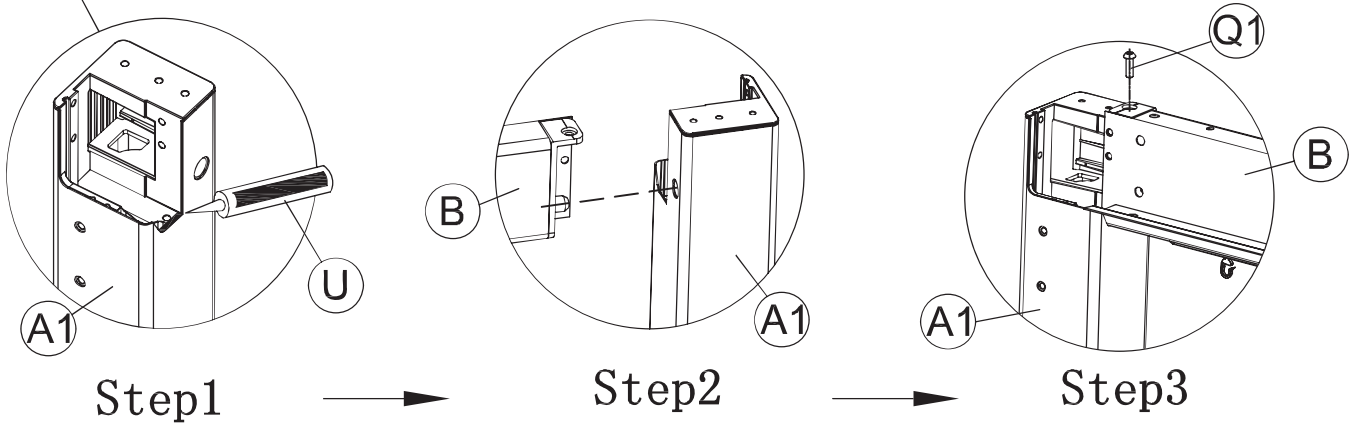
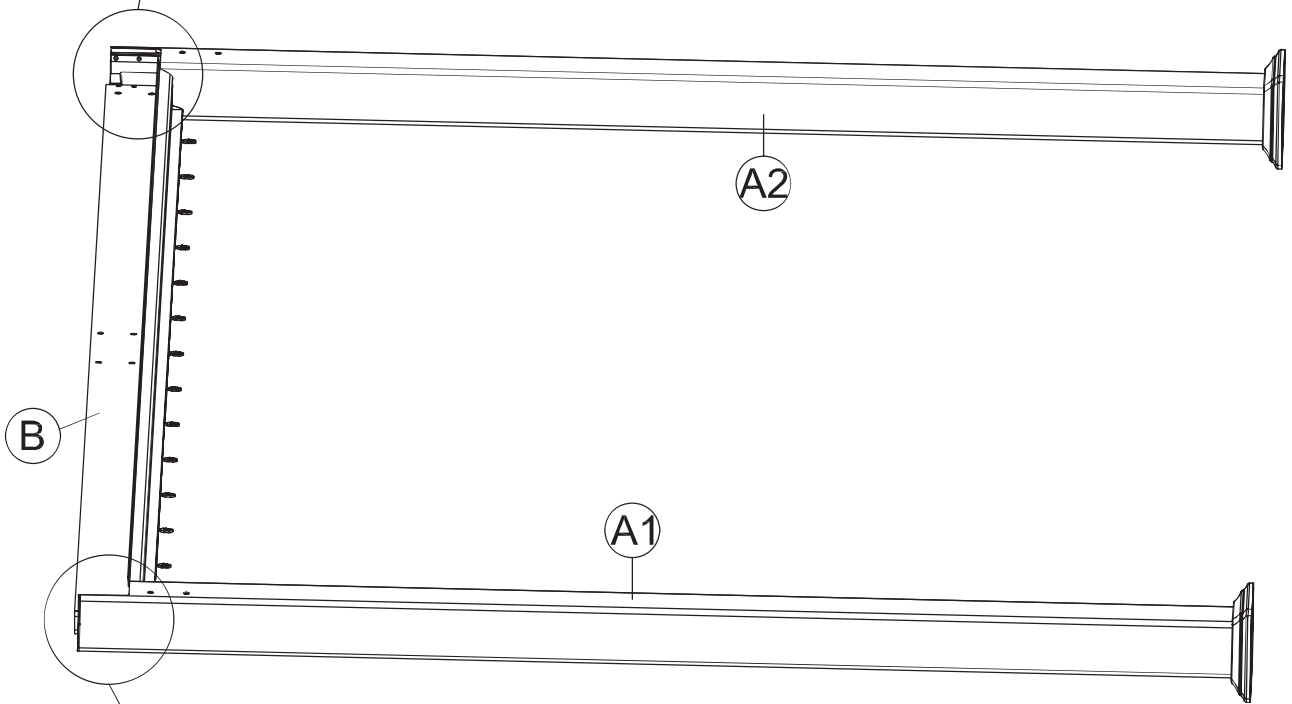
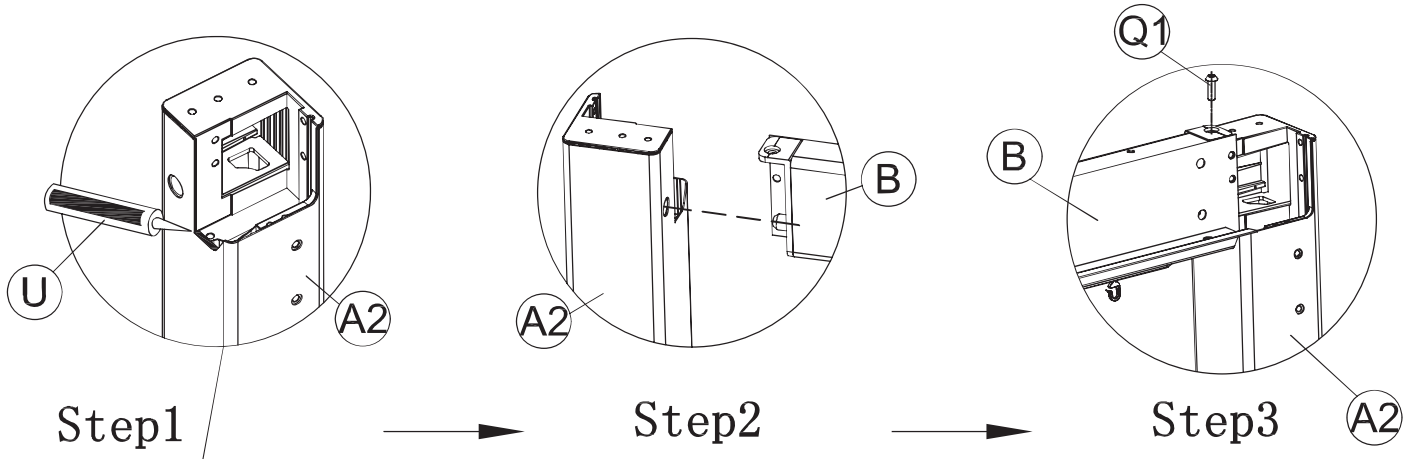

STEP 04

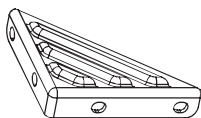
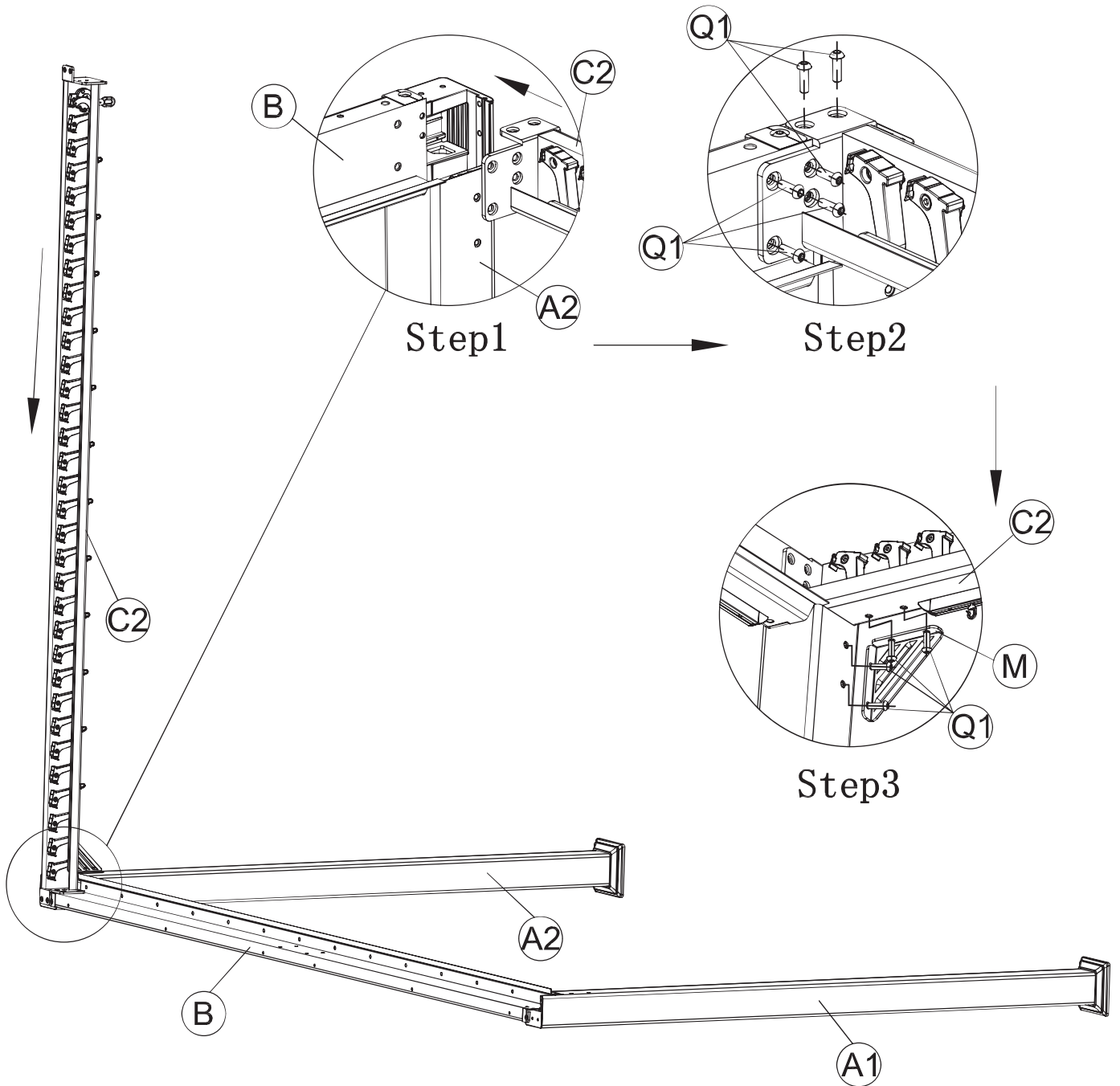

M (X1)



M8*20 Q1 (X10)

STEP 05

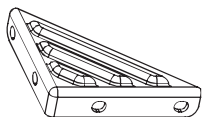
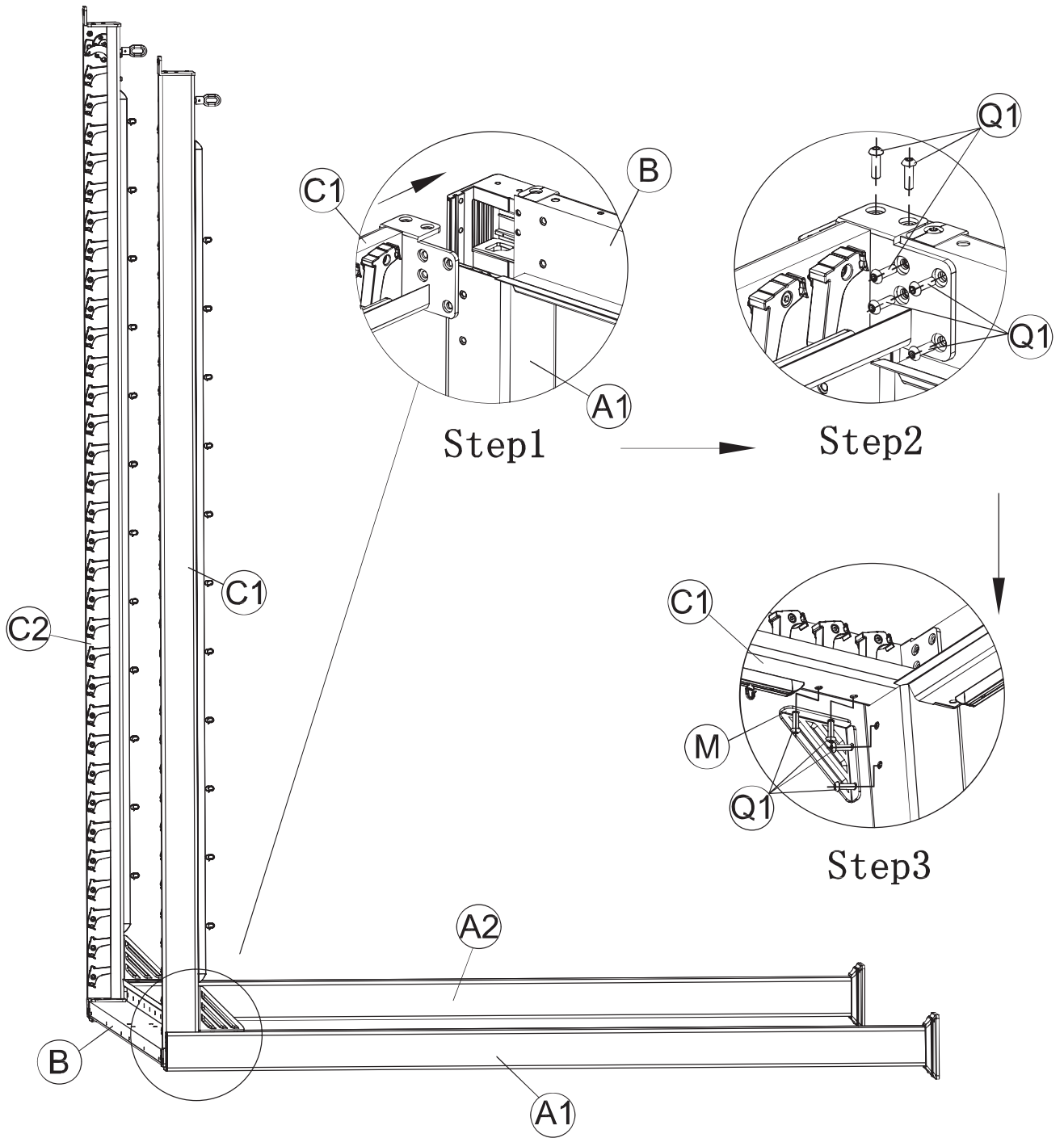

M (X1)



M8*20 Q1 (X10)

STEP 06

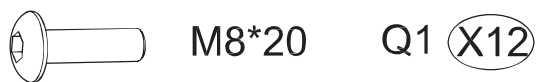
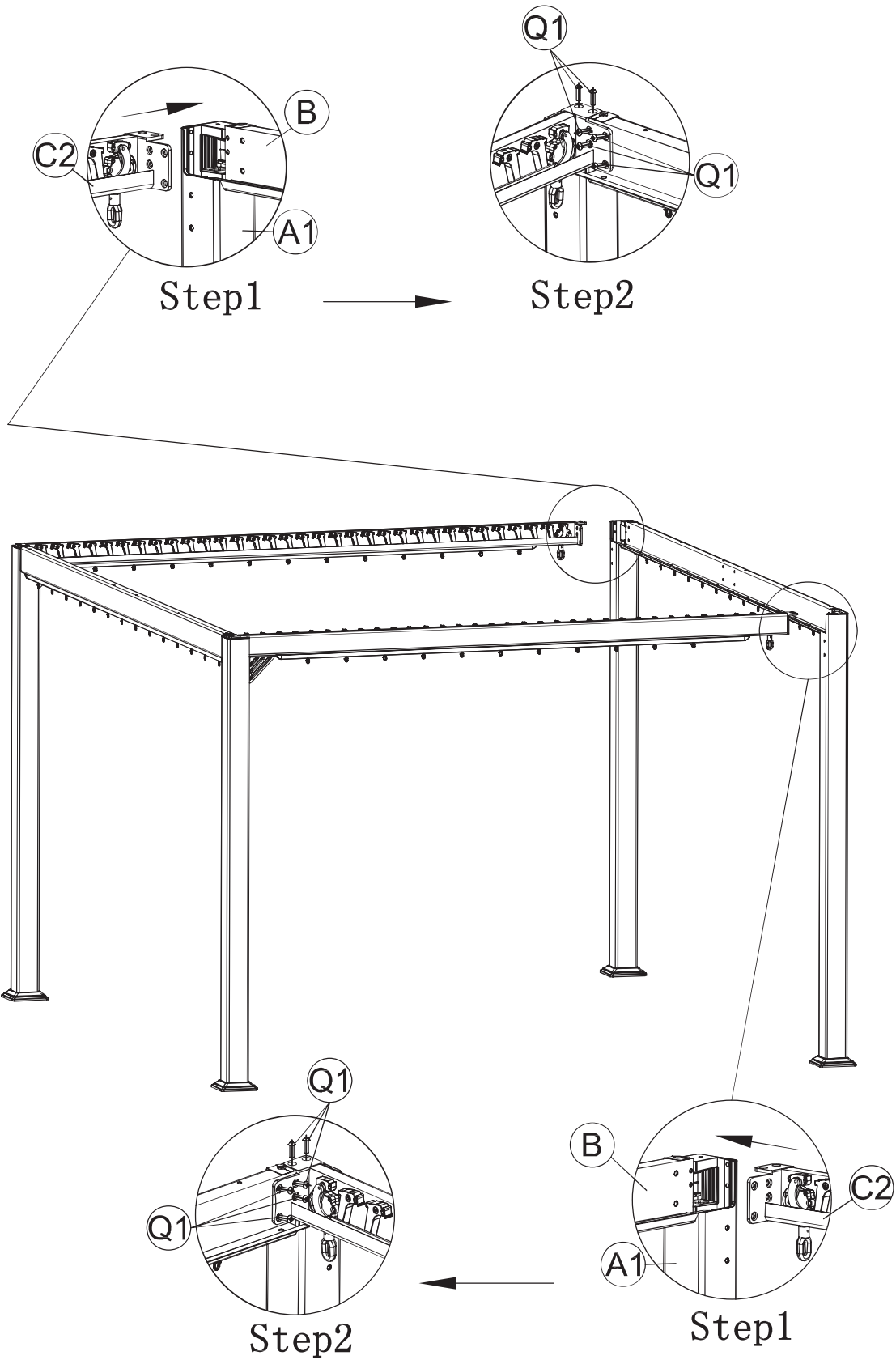

STEP 07

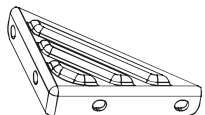
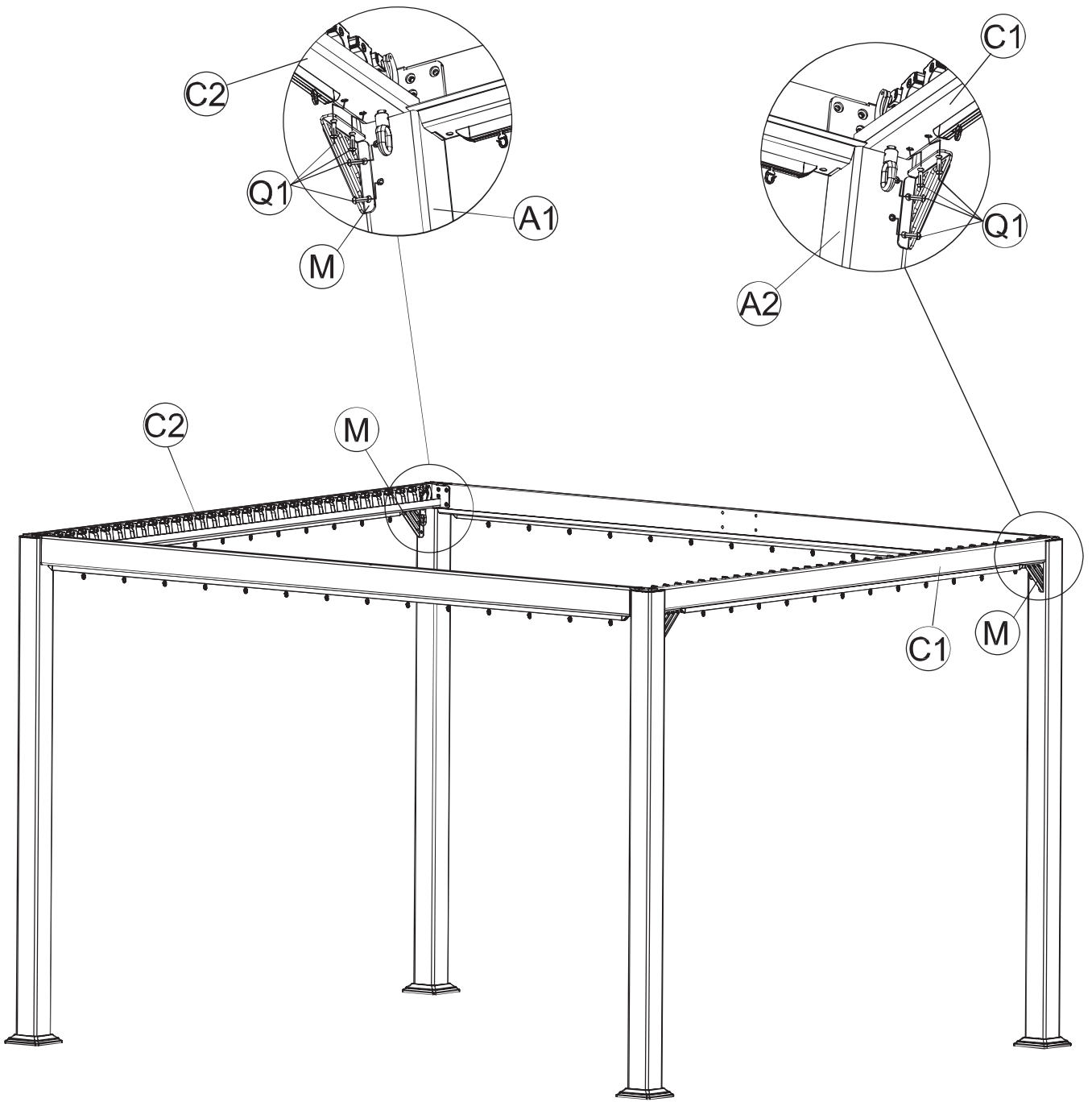



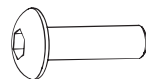

M (X2)

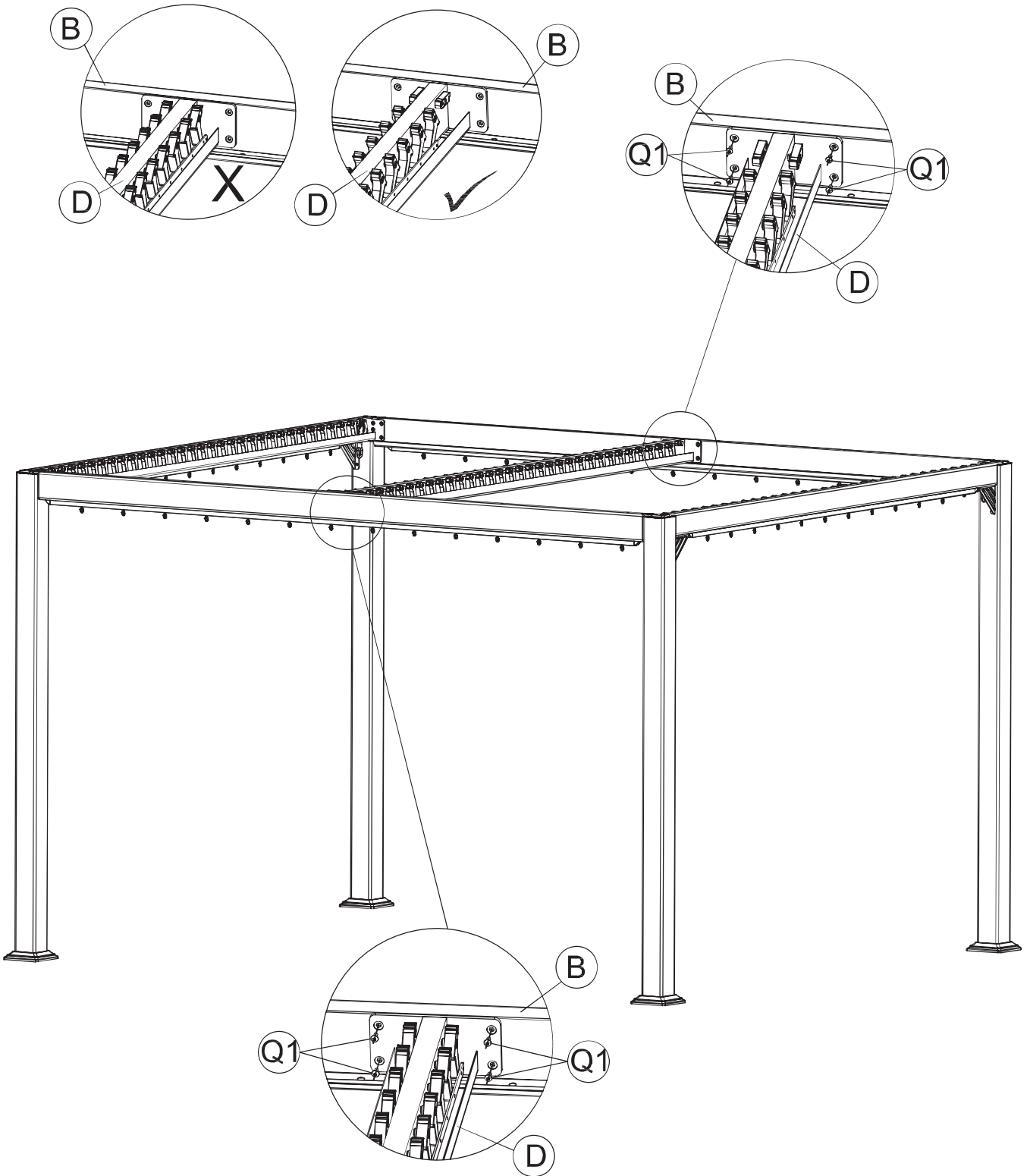

M8*20 Q1 (X8)

STEP 08



		D (X1)
	M8*20	Q1 (X8)

STEP 09

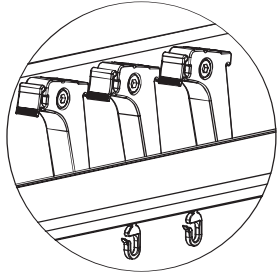

Step1

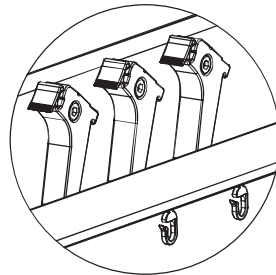

Step2

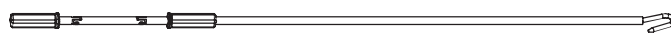
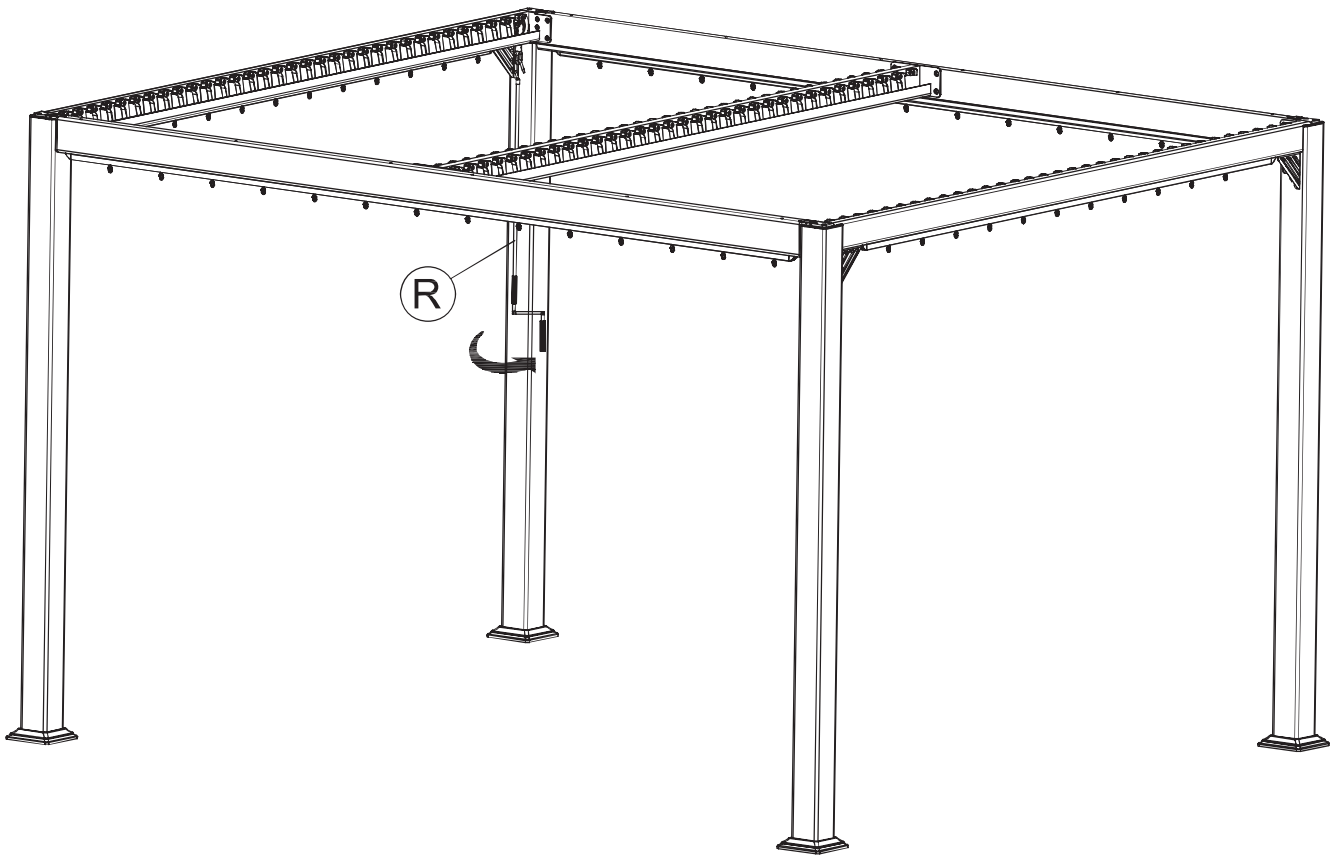

R X1

STEP 10

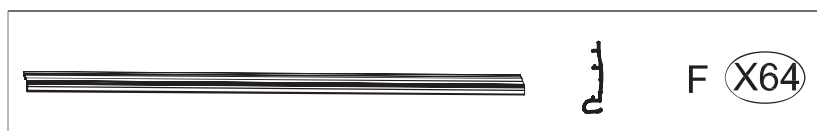
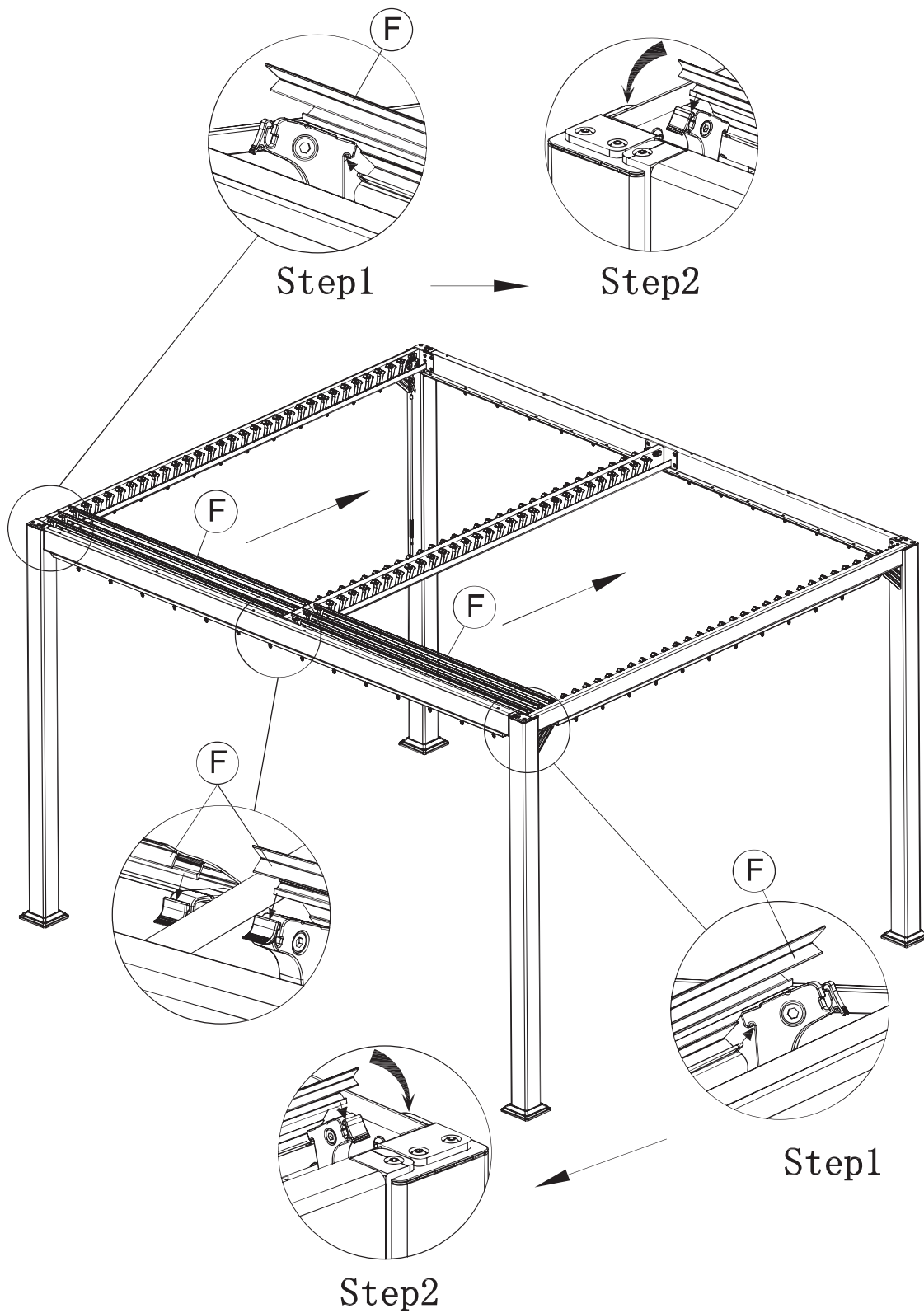

STEP 11

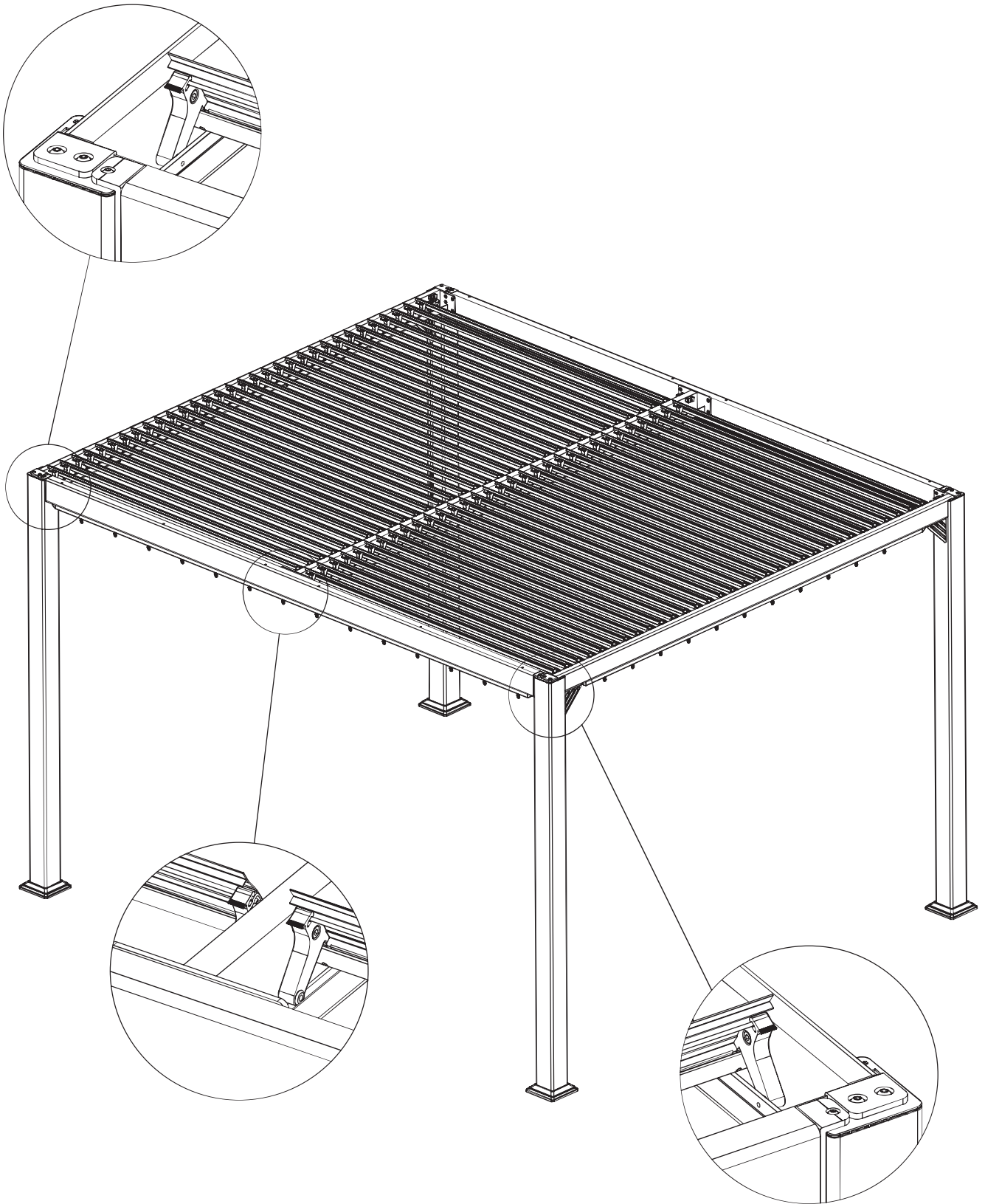

STEP 12

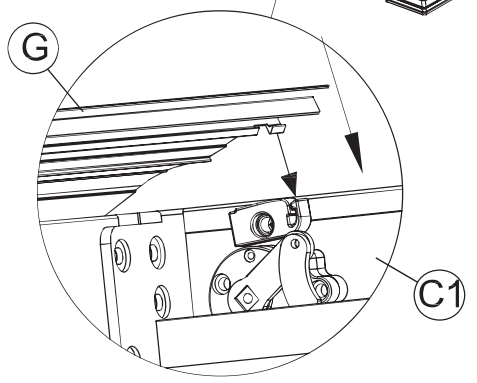
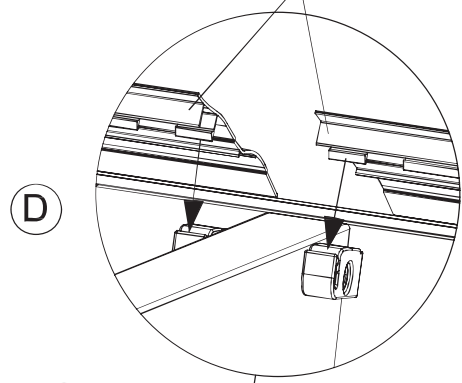
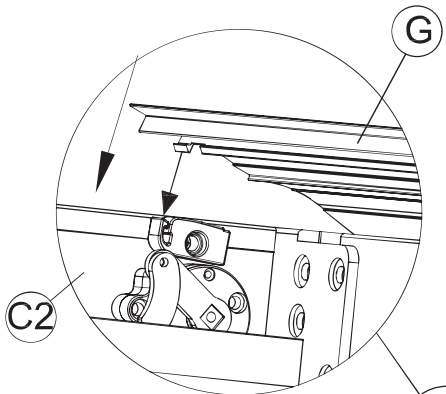
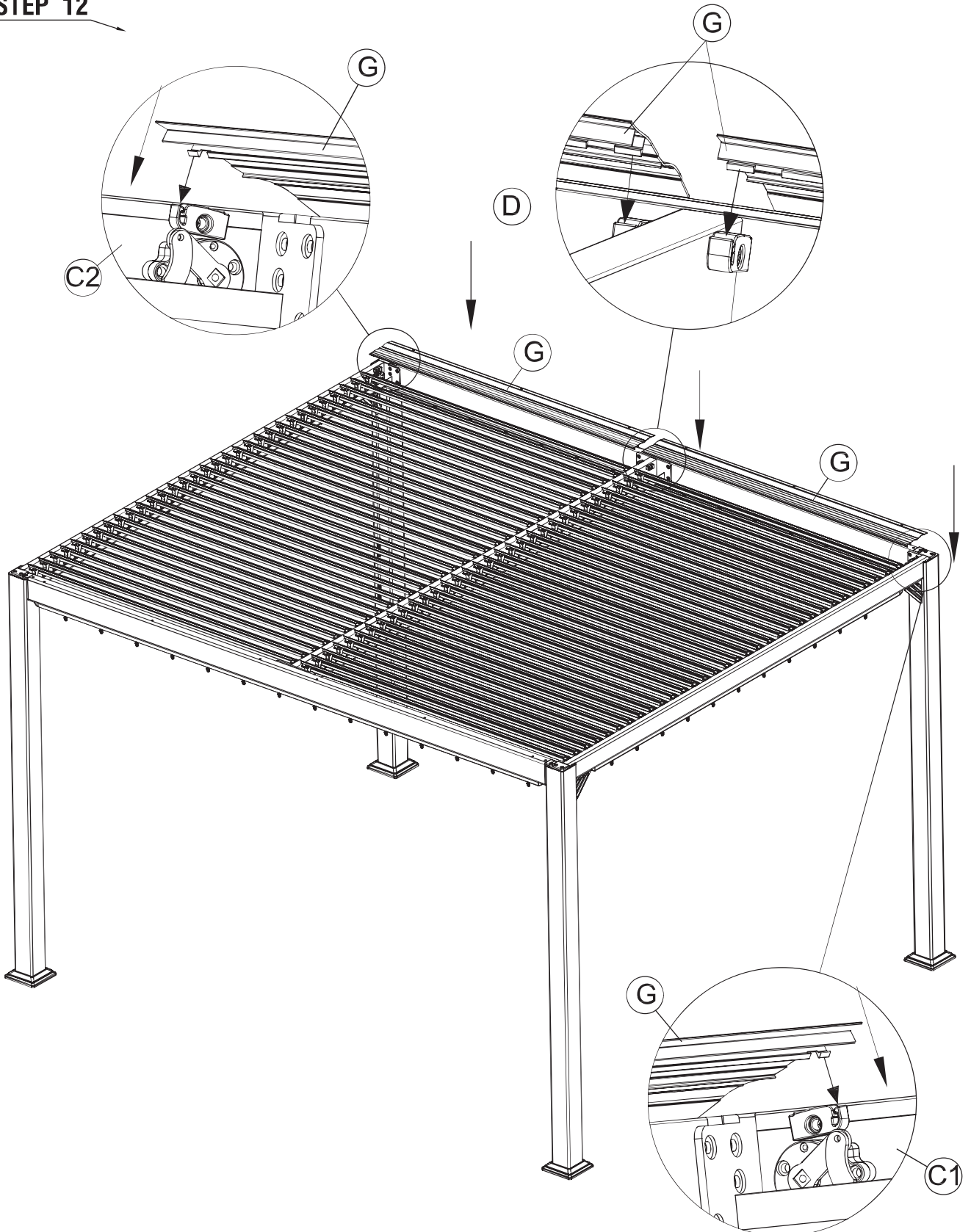

STEP 13

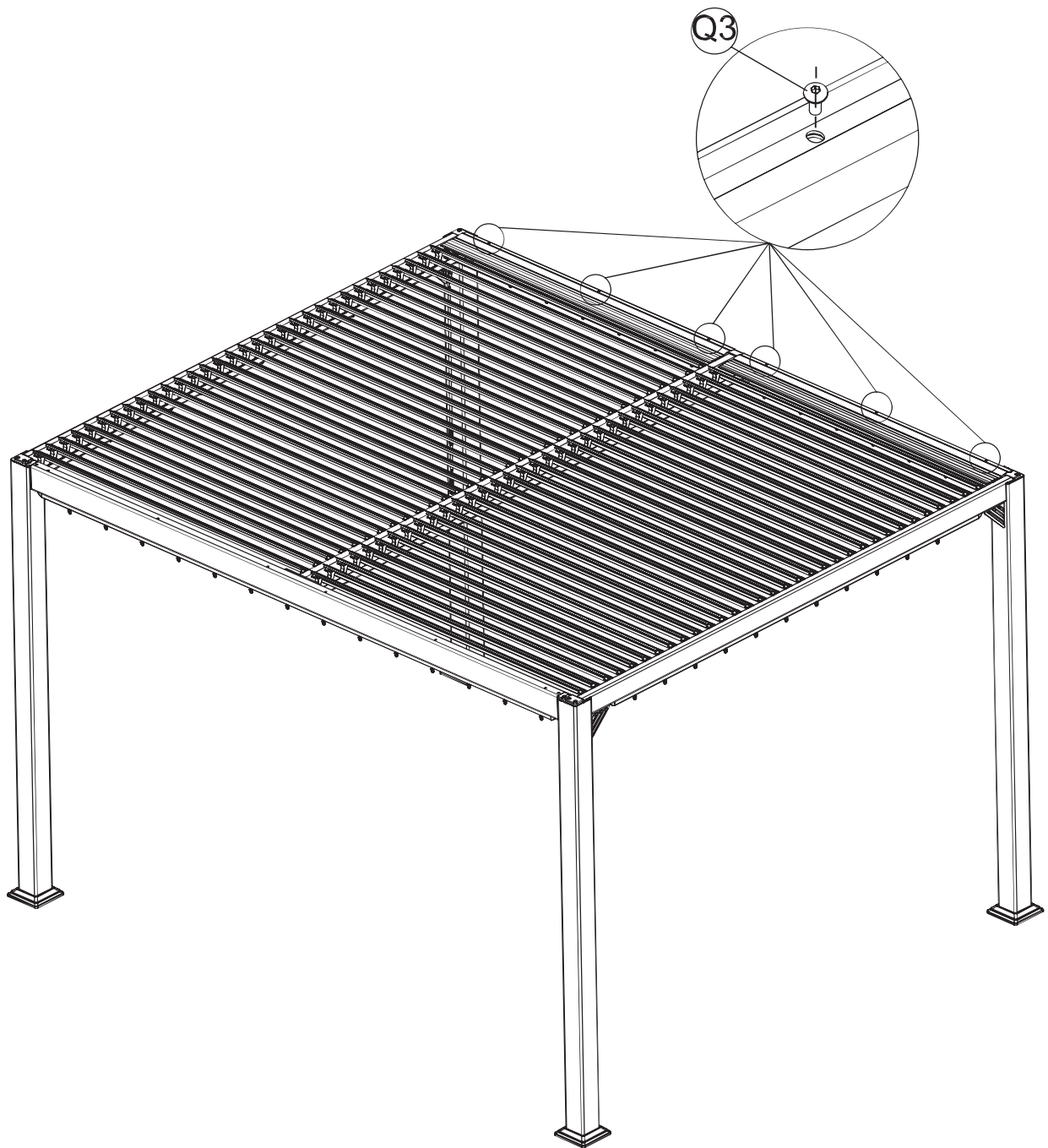

	M6*15	Q3 X6
---	-------	-------

STEP 14

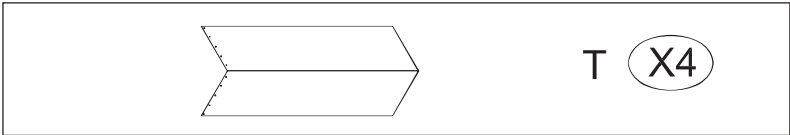
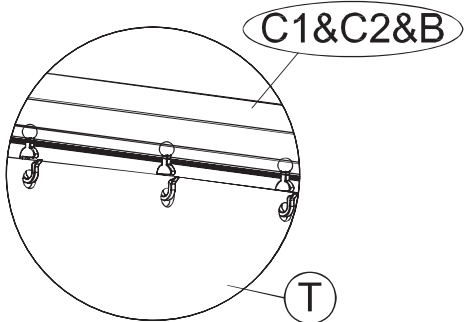
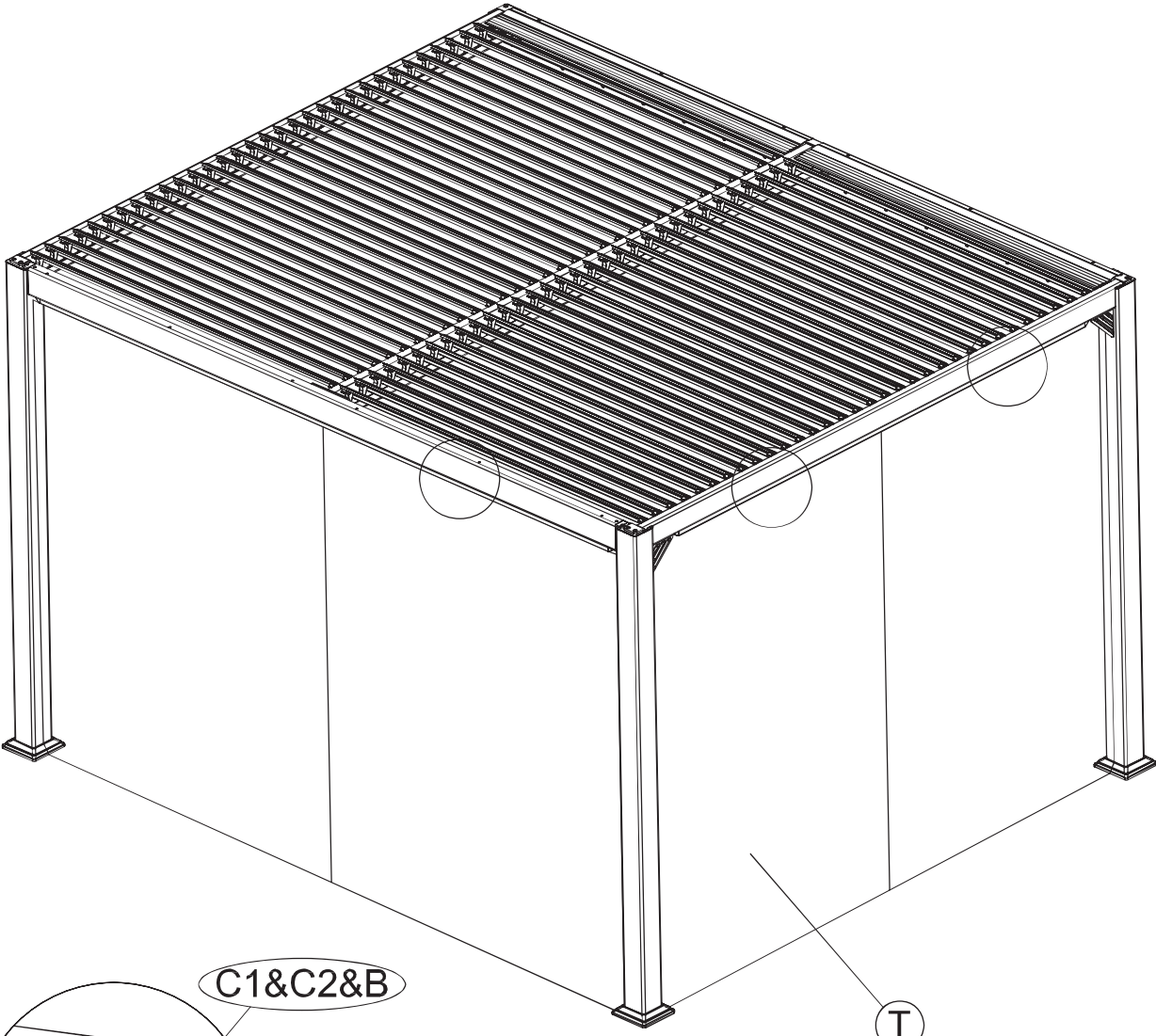

STEP 15

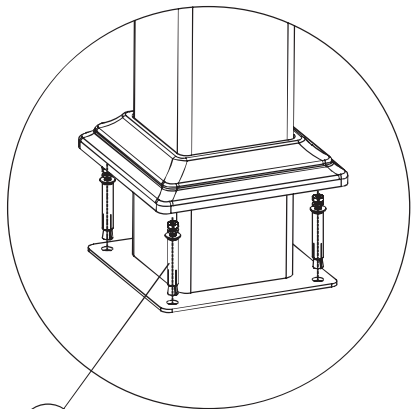
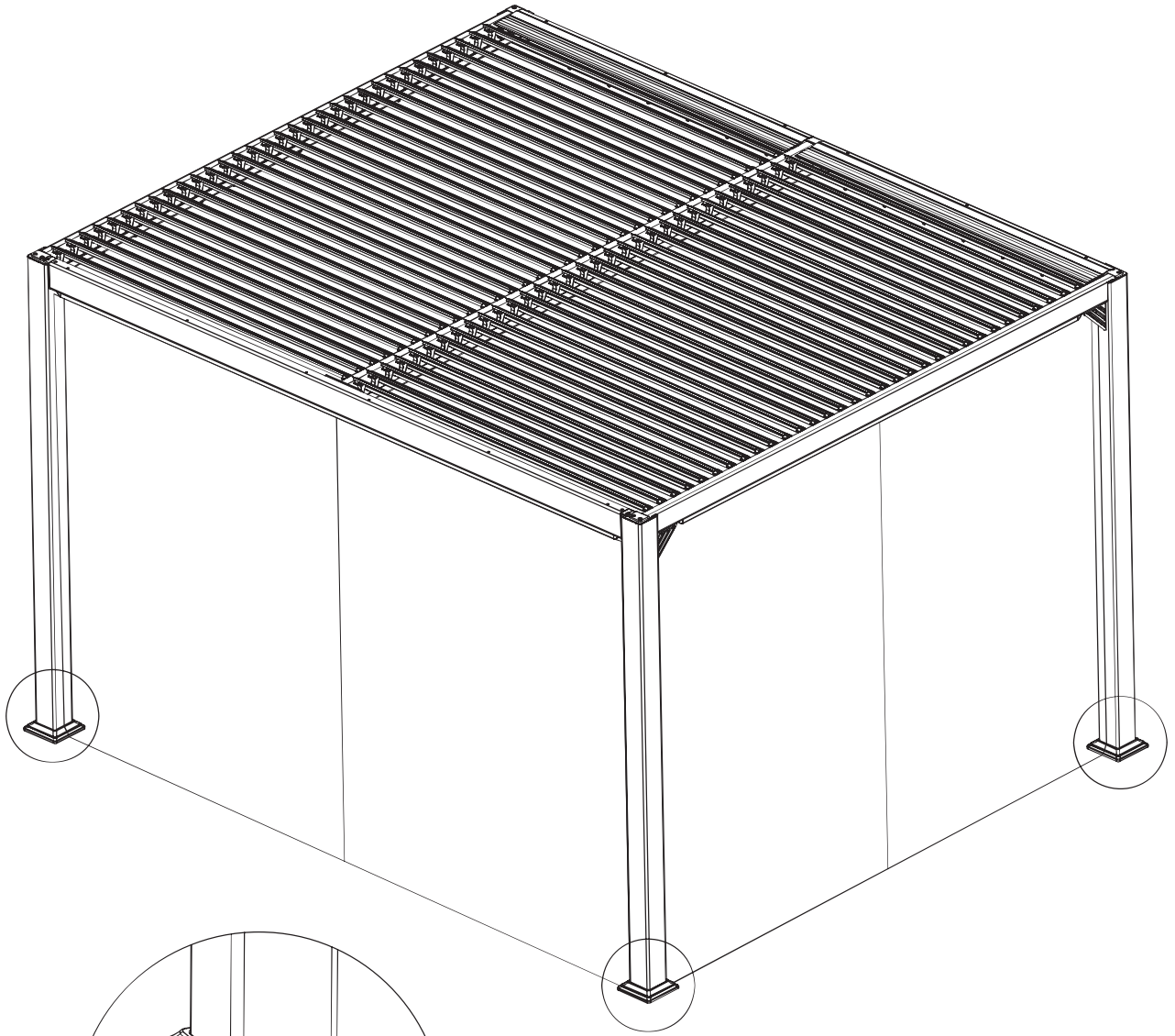

Q5

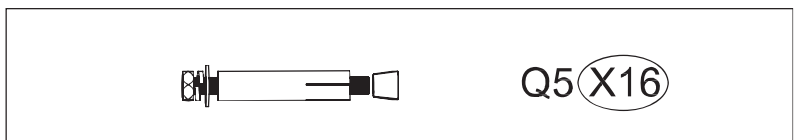

REMERCIEMENTS

Vous avez choisi d'acheter ce produit chez CREADOR. Nous espérons que vous en serez entièrement satisfait et vous remercions de votre confiance.

Si toutefois vous aviez remarqué un problème en cours de montage, appelez vite votre magasin qui vous apportera la solution adéquate.

Vous pouvez également nous écrire à l'adresse suivante :

WITH THANKS

You have decided to buy a product from **CREADOR**. We thank you for your trust and hope you are fully satisfied with your purchase.

If for any reason you encounter a problem when assembling this item, quickly call your shop which will provide you with a suitable solution.

You can also contact us at the following address :

DANKE

Sie haben beschlossen, dieses Produkt bei CREADOR zu kaufen. Wir hoffen, daß es Sie vollauf zufriedenstellt und danken Ihnen für Ihr Vertrauen.

Sollten Sie jedoch während der Montage auf ein Problem gestoßen sein, rufen Sie bitte schnell unser Geschäft an, das Ihnen die passende Lösung bringt.

Sie können uns auch unter folgender Adresse schreiben:

AGRADECIMIENTOS

Usted ha escogido comprar este producto en CREADOR. Esperamos que esté completamente satisfecho de eso y le agradecemos su confianza.

No obstante, si usted hubiese observado algún problema durante el montaje, lláme rápido a su tienda, ésta le dará la solución adecuada.

También puede escribirnos a la siguiente dirección :

AGRADECIMIENTOS

Você optou por comprar este produto CREADOR. Esperamos que você esteja completamente satisfeito com isso e agradecemos a sua confiança.

No entanto, se você tivesse visto algum problema durante a instalação, chame rápido a sua loja, ele vai te dar a solução certa.

Você também pode escrever para o seguinte endereço:

Importé par
MWH GMBH
Blindeisenweg 23
41468 Neuss
Allemagne
SAV France : sav.creator@mwhgmbh.de
Merci de joindre une photo et la facture d'achat



Ce meuble de jardin se recycle,
s'il n'est plus utilisable,
déposez-le en déchèterie.
Notice à trier.
Pour en savoir plus:
www.consignesdetri.fr

"Utilisation domestique uniquement"

"Positionnez le produit de manière stable sur une surface plane. Ne laissez pas les enfants manipuler ce produit. Ce produit doit être monté par un adulte. Tenez le produit à l'écart des flammes et des sources directes de chaleur telles que les radiateurs d'extérieurs et les barbecues. Ne pas rester sous ce produit en cas d'orage. Ne laissez pas les enfants jouer avec ce produit. Ne les laissez pas se suspendre à la structure. Lors de fortes intempéries, laissez les lames ouvertes. Ne pas laisser la neige s'accumuler sur la toiture. Bien fixer la structure au sol à l'aide de vis adaptées à la nature de votre sol et de préférence sur un socle en béton. En cas de doute, demandez conseil à un professionnel."

"For domestic use only""Always use on firm level ground. Do not let children play with this product. This product must be set up by a competent adult. Keep away from naked flames and direct sources of heat such as patio heaters and barbecues. Never stay under this product in thunderstorms. Do not hang from the frame and canopy of this product. When exposed to strong weather, leave the blades open. Do not let snow accumulate on the roof. Secure the structure to the ground with screws adapted to the nature of your floor and preferably on a concrete base. In case of any doubt ask a professional for advice."

"Nur für privaten Gebrauch""Nur auf festem Untergrund zu gebrauchen. Dies ist kein Kinderspielzeug und muss von einem Erwachsenen errichtet werden. Bitte von offenen Flammen und Hitzequellen wie BBQs und Terrassenheizer fernhalten. Nicht während Gewitter benutzen. Bitte keine Gegenstände am Produkt aufhängen. Schnee bitte vom Dach entfernen. Sichern Sie die Struktur auf einem festen Grund mit geeigneten Schrauben und vorzugsweise auf einer Betonbasis. Im Zweifelsfall fragen Sie einen Fachmann um Rat."

"Alleen voor privé gebruik""Gebruik altijd op stevige grond. Laat kinderen niet met dit product spelen. Dit product moet door een bevoegde volwassene worden opgericht. Blijf weg van blote vlammen en directe bronnen van hitte, zoals terrasverwarmers en barbecue. Blijf nooit onder dit product in onweersbuien. Hang geen tegenstanden van het frame en de kap van dit product. Laat geen sneeuw op het dak ophopen. Bevestig de structuur op de grond met schroeven, afhankelijk van de aard van uw vloer en bij voorkeur op een betonnen basis. In geval van twijfel vraag een professional om advies."

"Para uso doméstico exclusivamente""Fijar siempre en un nivel plano. No dejar a los niños jugar con este producto. Este producto debe ser montado por un adulto competente. Mantener alejado de fuentes de calor, tales como estufas o barbacoas. No permanecer debajo de este producto mientras haya tormenta. No colgarse de la estructura o techo. En caso de fuertes lluvias, dejar las baldas abiertas. No dejar la nieve que se acumule en el techo. Asegurarse que la estructura esté bien fijada al suelo, con los tornillos apropiados a la naturaleza de su suelo, y preferiblemente con una base de cemento. En caso de cualquier duda, contactar con un profesional."

"Para uso doméstico exclusivamente""Utilize sempre em terreno plano firme. Não permita que crianças brinquem com este produto. Este produto deve ser instalado por um adulto competente. Manter afastado de fontes de calor, como aquecedores ou churrasqueiras. Não fique sob este produto enquanto há uma tempestade. Não pendurar na estrutura do telhado. En caso de fuertes lluvias, dejar las baldas abiertas. Não deixe a neve se acumula no telhado. Certifique-se de que a estrutura está corretamente fixada ao solo, com os parafusos apropriados à natureza do seu piso e, de preferência, com uma base de cimento. Em caso de dúvida, entre em contato com um profissional."

Pour nettoyer la surface du produit et retirer toute tâche ou moisissure, utilisez un mélange d'eau chaude et de détergent doux sur un chiffon humide. Séchez à l'aide d'un chiffon propre. N'utilisez jamais de solvants, de produits à récurer, d'abrasifs, de javel, d'acides, de détergents puissants, chimiques agressifs ou à base de solvant sur le produit.

Ne pas utiliser de nettoyeur haute pression sur ce produit.

A monter soi même

Use warm water with a mild detergent and a soft damp cloth to clean the surface of the product and to remove any stains or mildew. Wipe dry with a clean cloth. Never use any solvents, scourers, abrasives, bleach, acids, strong detergents, aggressive chemical cleaners or solvent-type cleaning solutions on the product.

Do not use a high-pressure washer for cleaning of this product.

Easy self-assembly

Verwenden Sie warmes Wasser mit einem milden Reinigungsmittel und einem weichen, feuchten Tuch, um die Oberfläche des Produkts zu reinigen und um Flecken oder Schimmel zu entfernen. Mit einem sauberen Tuch abwischen

Verwenden Sie niemals Lösungsmittel, Scheuermittel, Schleifmittel, Bleichmittel, Säuren, starke Reinigungsmittel, aggressive chemische Reiniger oder lösemittelhaltige Reinigungslösungen auf dem Produkt. Verwenden Sie zur Reinigung dieses Produkts keinen Hochdruckreiniger. Einfache Selbstmontage

Gebruik warm water met een mild reinigingsmiddel en een zachte vochtige doek om het oppervlak van het product schoon te maken en eventuele vlekken te verwijderen. Veeg droog met een schone doek.

Gebruik nooit oplosmiddelen, schuurmiddelen, bleekmiddel, zuren, sterke reinigingsmiddelen, agressieve chemische reinigers of reinigungsoplossingen op het product.

Gebruik geen hogedrukreiniger voor het schoonmaken van dit product. Eenvoudig zelf te monteren

Use agua tibia con un detergente suave, y un paño suave y húmedo, para limpiar la superficie del producto y eliminar cualquier mancha o moho. Seque con un paño limpio.

Nunca utilice disolventes, esponjas, abrasivos, lejía, ácidos, detergentes fuertes, limpiadores químicos agresivos o soluciones de limpieza de tipo disolvente en el producto.

No utilice una lavadora de alta presión para la limpieza de este producto.

Montaje sencillo

Usar água quente com um detergente suave, e um pano húmido e macio para limpar a superfície do produto e remover quaisquer manchas ou oxidação. Seque com um pano limpo.

Nunca utilizar solventes, esponjas, abrasivos, agentes de branqueamento, ácidos, detergentes fortes, produtos de limpeza ou soluções de limpeza químicos agressivos em tipo de solvente do produto.

Não use uma lavadora de alta pressão para limpar este produto.

Facil montagem